



**PTH GROUP s.r.l.** - Via Ticino 15 - 21043 Castiglione Olona (VA) - ITALY  
Tel +39 0331 858378 - Fax +39 0331 824390 - E-mail: [info@pth-group.com](mailto:info@pth-group.com)  
Web site: [www.pth-group.com](http://www.pth-group.com)

## **EXTRUDED PLASTIC PROFILES FOR BUS AND TRAIN**

**Some drawings of this catalogue are exclusive property of our customers**

# PTM

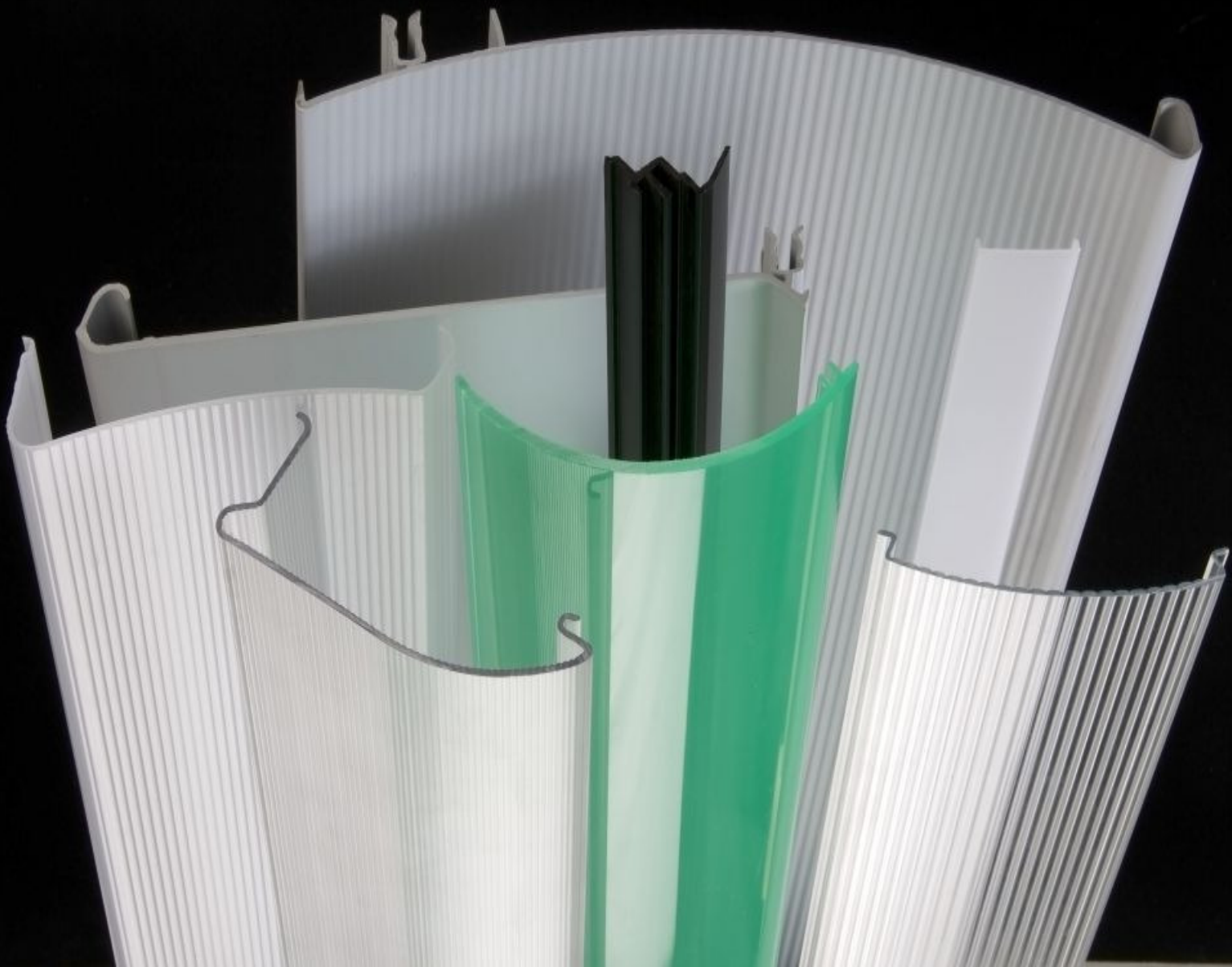

# PLASTIC PROFILES FOR BUS AND TRAIN

**Profile 4010.01**  
**Material : BLEND**

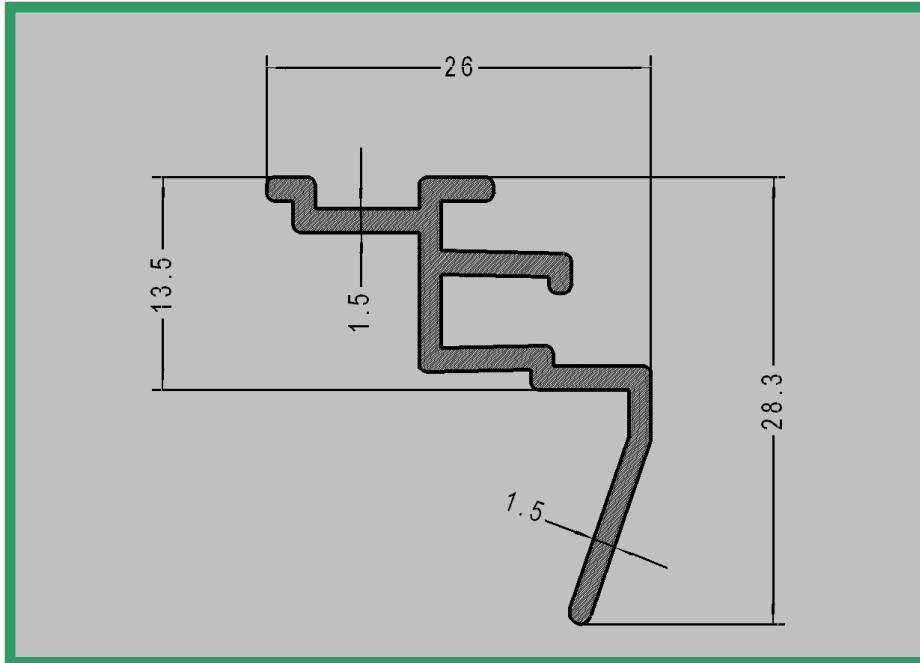

**Profile 4010.03**  
**Material : ABS**

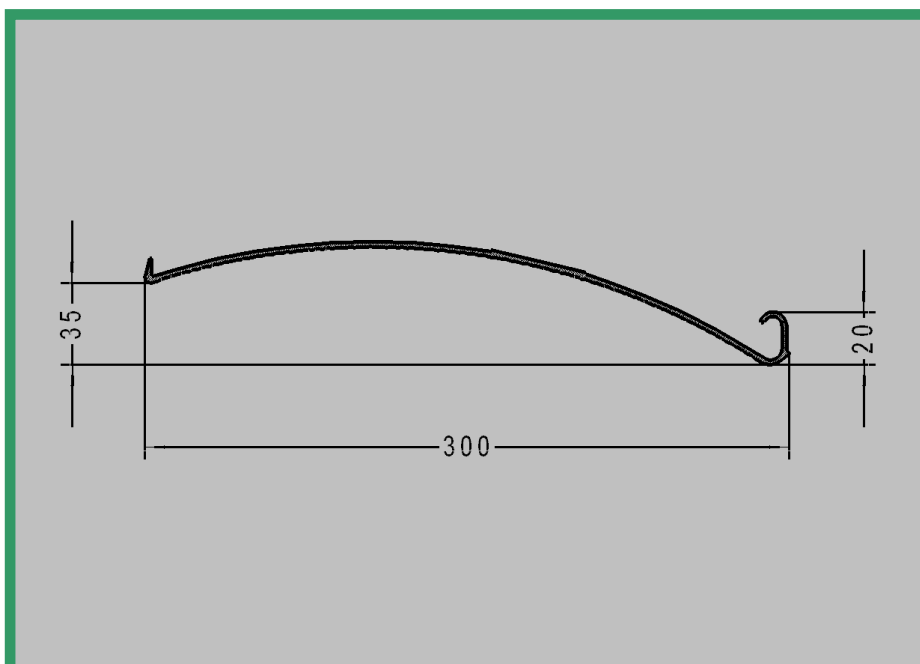

# PLASTIC PROFILES FOR BUS AND TRAIN

**Profile 4010.04**

**Material : ABS**

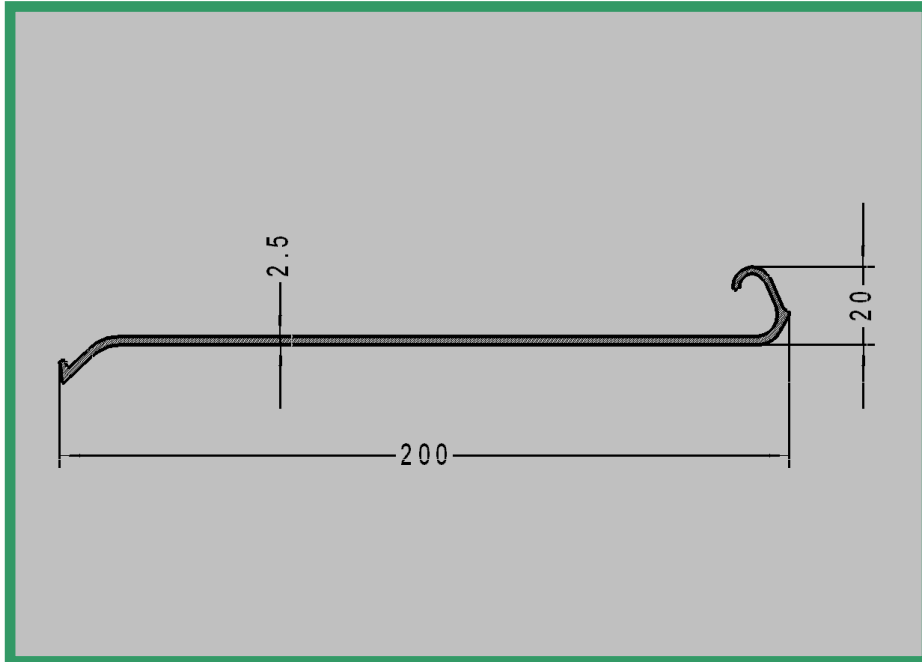

**Profile 1010.36**

**Material : POLYCARBONATE**

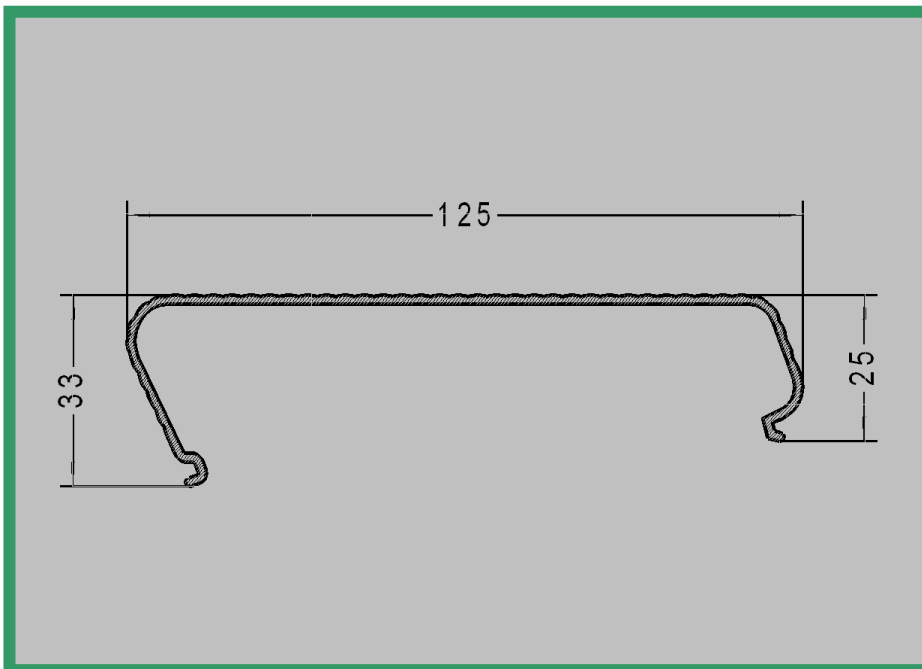

# PLASTIC PROFILES FOR BUS AND TRAIN

**Profile 4010.07**  
**Material : POLYCARBONATE**

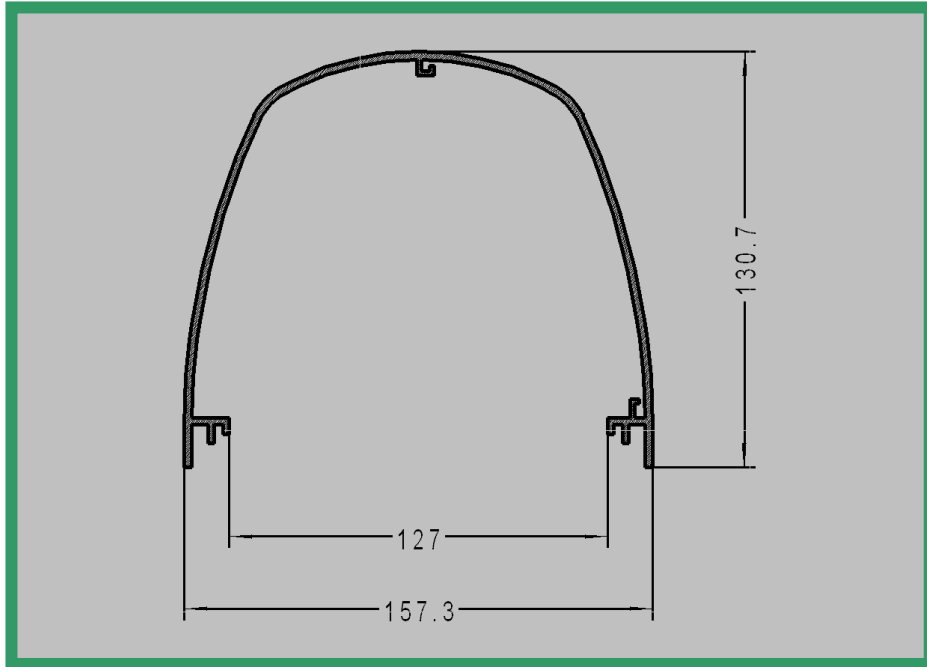

**Profile 1010.121**  
**Material : POLYCARBONATE**

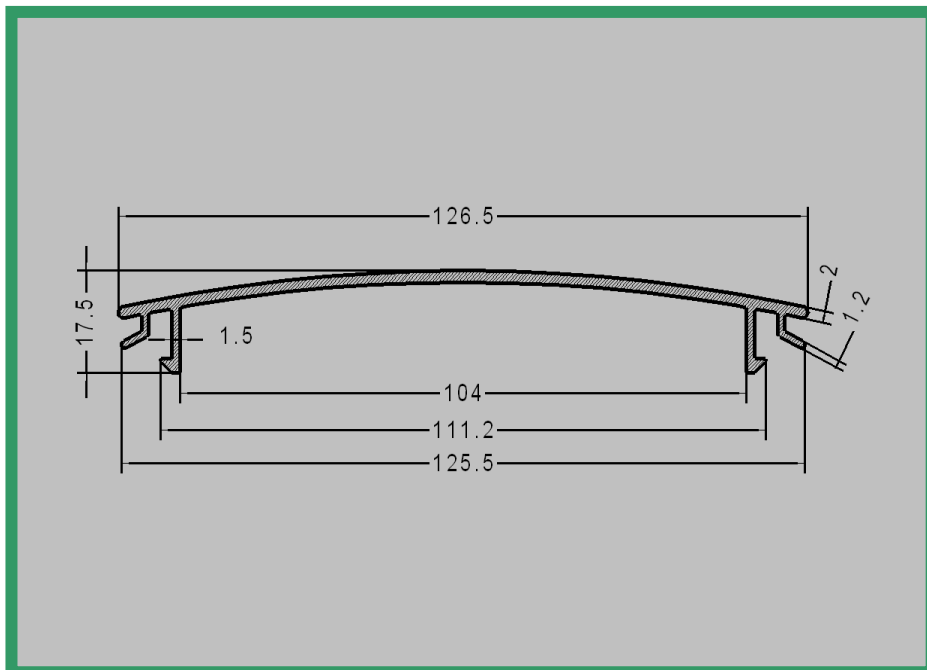

# PLASTIC PROFILES FOR BUS AND TRAIN

**Profile 1010.122**

**Material : ABS**

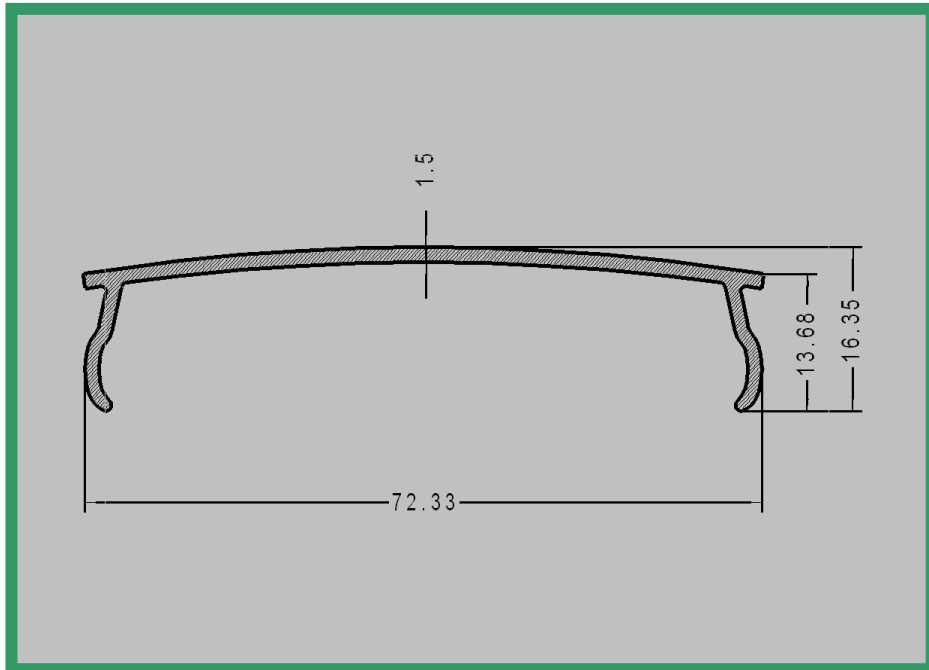

**Profile 1010.124**

**Material : ABS**

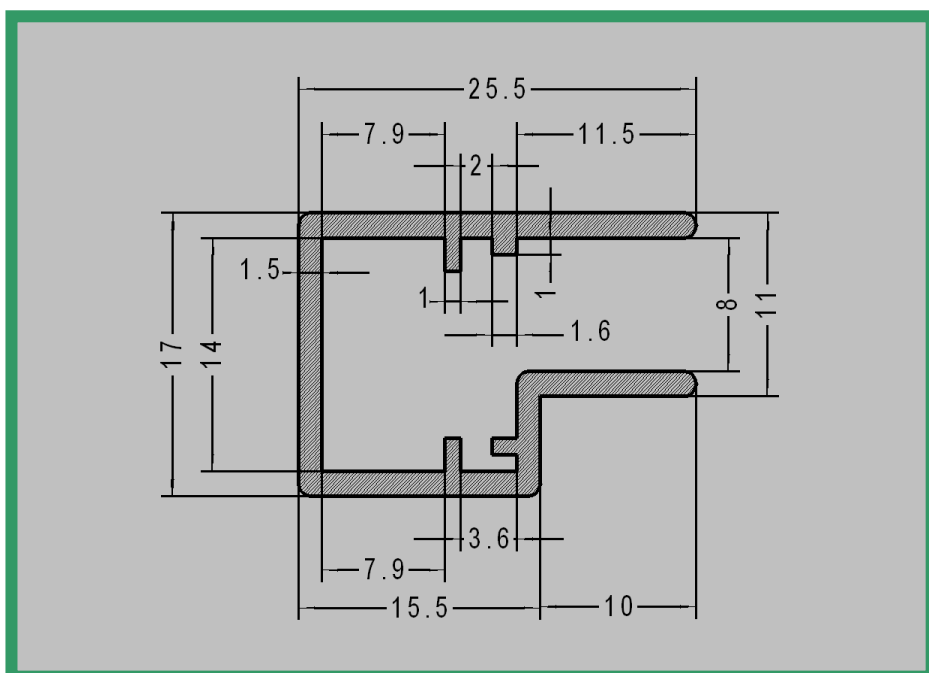

# PLASTIC PROFILES FOR BUS AND TRAIN

**Profile 1010.129**  
**Material : POLYCARBONATE**

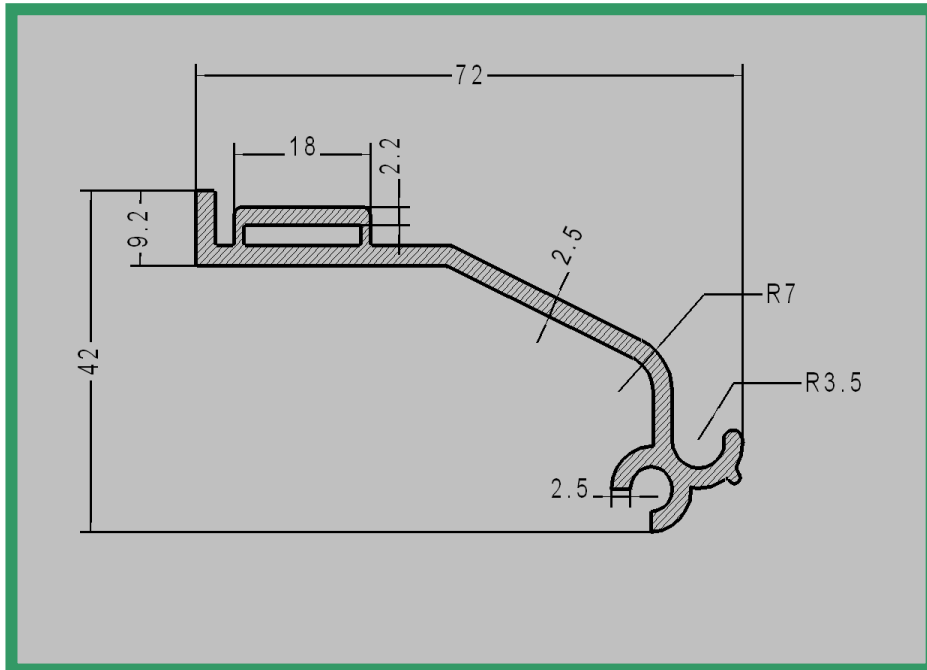

**Profile 1010.133**  
**Material : POLYCARBONATE**

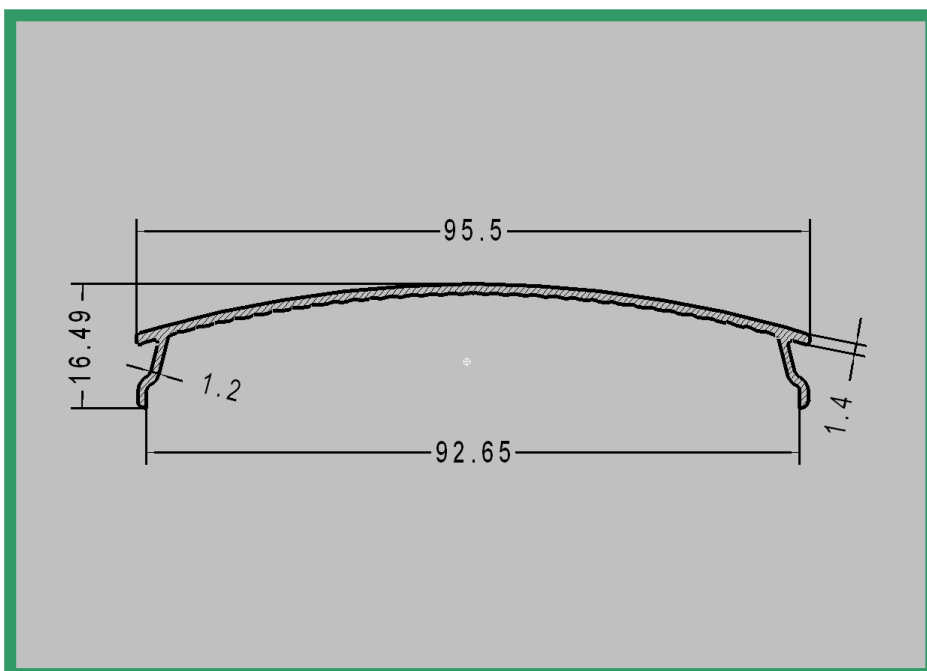

# PLASTIC PROFILES FOR BUS AND TRAIN

**Profile 1010.137**  
**Material : POLYCARBONATE**

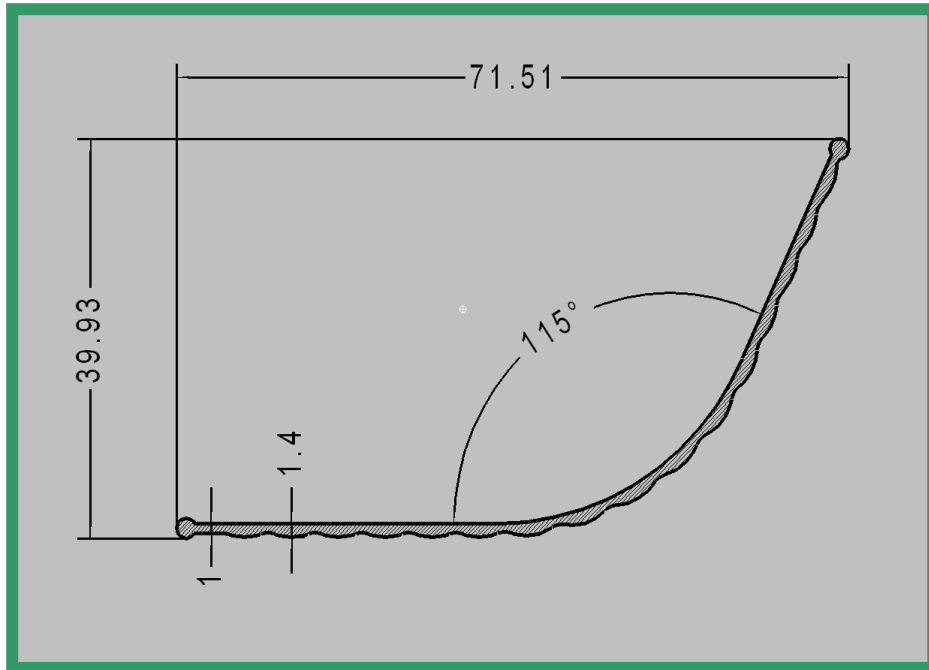

# DATA SHEET TECHNICAL MATERIAL

## POLYCARBONATE

<b>PC UV RESISTANT ANTISHOCK</b>	<b>NOMINAL VALUE (English)</b>	<b>NOMINAL VALUE (SI)</b>	<b>TEST METHOD</b>
<b>PHYSICAL</b>			
Density	1.20 g/cm <sup>3</sup>	1.20 g/cm <sup>3</sup>	ASTM D792
<b>THERMAL</b>			
Deflection Temperature Under Load 66 psi (0.45 MPa), Unannealed	275 °F	135 C	ASTM D648
Deflection Temperature Under Load 264 psi (1.8 MPa), Unannealed	268 °F	131 C	ASTM D648
Vicat Softening Point	307 °F	153 C	ASTM D1525
CLTE, Flow	0.000039 in/in/°F	0.000070 cm/cm/°C	ASTM D696
Specific Heat	0.280 Btu/lb/°F	1170 J/kg/°C	ASTM C351
Thermal Conductivity	1.3 Btu in/hr/ft <sup>2</sup> /°F	0.19 W/m/K	ASTM C177
<b>FLAMMABILITY</b>			
Flame Rating – UL			UL 94
0.0625 in (1.59 mm)	HB	HB	
0.125in(3.18mm)	V-2	V-2	
0.250 in (6.35 mm)	V-0	V-0	
Oxygen index	24%	24%	ASTM D2863
<b>OPTICAL</b>			
Refractive index	1.586	1.586	ASTM D542
Transmittance	87.0 %	87.0 %	ASTM D1003
Haze	1.0 %	1.0 %	ASTM D1003

# POLYCARBONATE

<b>PC UV RESISTANT ANTISHOCK V0</b>	<b>NOMINAL VALUE (English)</b>	<b>NOMINAL VALUE (SI)</b>	<b>TEST METHOD</b>
<b>PHYSICAL</b>			
Density	1.25 g/cm <sup>3</sup>	1.25 g/cm <sup>3</sup>	ISO 1183
<b>THERMAL</b>			
Heat Deflection Temperature 6 66 psi (0.45 MPa), Unannealed	291 °F	144 °C	ISO 75B-1, -2
Heat Defiection Temperature 6 264 psi (1.8 MPa), Unannealed	268 °F	131 °C	ISO 75A-1, -2
Vicat Softening Temperature A50(50C/h10N)	311 °F	155 °C	ISO 306
B120 (120C/h 50N)	306 °F	152 °C	
B50 (50C/h 50N)	302 °F	150 °C	
Coefficient of Linear Thermal Expansion, Flow  73 to 176SF (23° to 80°C)	0.000039 in/in/°F 1.4 Btu in/hr/ft <sup>2</sup> /°F	0.000070 cm/cm/°C	ISO 11359-1, -2  ISO 8302
Thermal Conductivity		0.20 W/m/K	
<b>OPTICAL</b>			
Refractive index	1.586	1.586	ISO 489
Transmittance	88.0 to 90.0 %	88.0 to 90.0 %	ASTM D1003
Haze	< 0.80 %	< 0.80 %	ASTM D1003
<b>FLAMMABILITY</b>			
Flame Rating – UL 0.0591 in (1.50 mm) 0.0984 in (2.50 mm)	V-2 V-0	V-2 V-0	UL 94
Glow Wire Flammability Index  0.0394 in (1.000 mm)	1560 °F	850 °C	IEC 60695-2-12

## PMMA

<b>PMMA - UV RESISTANT</b>	<b>CONDITIONS</b>	<b>TEST METHOD</b>	<b>UNITS</b>	<b>VALUE</b>
<b>GENERAL PROPERTIES</b>				
Density		ISO 1183	g/cm <sup>3</sup>	1,18
<b>THERMAL PROPERTIES</b>				
Vicat Softening Temperature	50 N	ISO 306	°C	101
Coefficient of linear expansion		ASTM D-696	10 <sup>-6</sup> K	65
HDT UFL	1,82 Mpa	ISO 75-2	°C	92
<b>OPTICAL PROPERTIES</b>				
Refractive Index B		ISO R-489		1,49
Light Transmittance		ASTM D-1003	%	92
Haze		ASTM D-1003	%	0,5
<b>FLAMMABILITY</b>				
Fire Resistance		ASTM UL/94		HB

<b>PMMA - UV RESISTANT HIGH IMPACT</b>	<b>CONDITIONS</b>	<b>TEST METHOD</b>	<b>UNITS</b>	<b>VALUE</b>
<b>GENERAL PROPERTIES</b>				
Density		ISO 1183	g/cm <sup>3</sup>	1,15
<b>THERMAL PROPERTIES</b>				
Vicat Softening Temperature	50 N	ISO 306	°C	100
Coefficient of linear expansion	[-30 °C, 23 °C]	ASTM D-696	10 <sup>-6</sup> K	100
HDT	1,82 Mpa	ISO 75-2	°C	88
	0,45 Mpa			93
Specific Heat			J/(Kg. °C)	2093
<b>OPTICAL PROPERTIES</b>				
Refractive Index B		ISO R-489		1,49
Light Transmittance		ASTM D-1003	%	90
Haze		ASTM D-1003	%	2
<b>FLAMMABILITY</b>				
Fire Resistance		ASTM UL/94	Class	HB

<b>PMMA - SATIN UV RESISTANT</b>	<b>CONDITIONS</b>	<b>TEST METHOD</b>	<b>UNITS</b>	<b>VALUE</b>
<b>GENERAL PROPERTIES</b>				
Density		ISO 1183	g/cm <sup>3</sup>	1,18
<b>THERMAL PROPERTIES</b>				
Vicat Softening Temperature	50 N	ISO 306	°C	103
Coefficient of linear expansion		ASTM D-696	10 <sup>-6</sup> K	65
HDT UFL	1,82 Mpa	ISO 75-2	°C	95
<b>OPTICAL PROPERTIES</b>				
Refractive Index B		ISO R-489		1,49
Light Transmittance		ASTM D-1003	%	87
Haze		ASTM D-1003	%	100
<b>FLAMMABILITY</b>				
Fire Resistance		ASTM UL/94		HB